

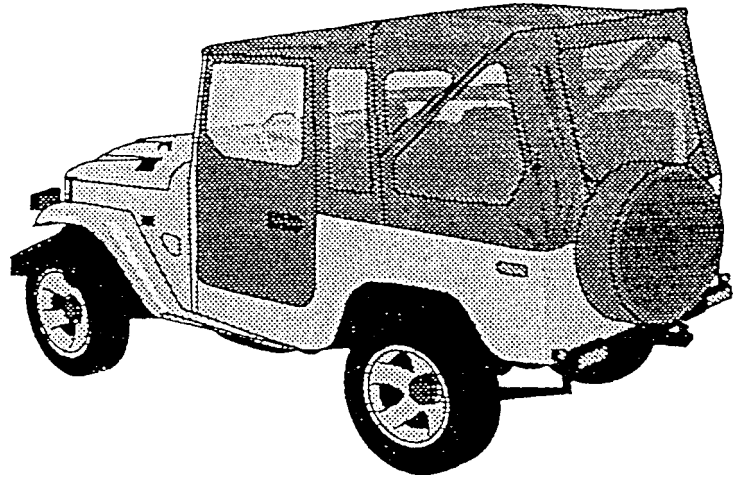

21600 NORDHOFF ST.
CHATSWORTH, CALIFORNIA 91311 USA
PH: (818) 882-1238 FAX: (818) 882-7144
E-Mail: sor@sor.com
Internet: <http://www.sor.com>

#270-40 SPECTER TIGER TOP INSTALLATION INSTRUCTIONS



Part Number: 51444

Model: Toyota Land Cruiser, FJ40, BJ40, 1964-1984. Top Kit, Soft Doors Included.

NOTE: Use of this product on some vehicles may not allow the use of factory side mirrors.

Use of this product on some vehicles may require the removal of the entry light bulbs.

On vehicles built after 1975 that have never had a soft top, a metal tailgate panel will need to be ordered. Order Part Number 51042-01. (Removing the hard top also removes the tailgate.)

INSTALLATION INSTRUCTIONS AND OWNER'S MANUAL

Congratulations on your purchasing decision. Bestop designed this Convertible Top to give you years of dependability and performance with proper care. If you encounter any problems during the installation of your Convertible Top, or at any later date, please contact Specter Off Road or call our Consumer Response Department, Monday-Friday 8am-4:30pm (MST) at 1-800-346-3910 or (303) 465-1755 in Colorado.

NOTE: Please read this manual thoroughly before beginning the installation. After completing installation, keep this manual for future reference.

WARNING

This product is designed to enhance the appearance of the vehicle and to shield the occupants from ordinary weather conditions. The safety characteristics of this product are extremely limited. Do not rely, in any way, on the components of this product to contain occupants within the vehicle, or to protect against injury or death in the event of an accident. This top will not protect the occupants from falling objects. Never operate vehicle in excess of manufacturer's specifications.

WEAR SEAT BELTS AT ALL TIMES

Read and follow, precisely, all installation instructions provided when installing top. Failure to do so may result in a poor fitting top and could place occupants of the vehicle in a potentially dangerous situation.



BEFORE YOU INSTALL

You may notice some wrinkling in the fabric of your Convertible Top when you first remove it from its shipping container. Also, there may be indentations in the windows. **DO NOT PANIC.** It is normal for the tops to do this when stored in the shipping container. The wrinkles and indentations will disappear after 48-72 hours of exposure to sunlight.

NOTE: You should install your Convertible Top in temperatures of 70°F (21°C) or warmer. The fabric will contract in cooler temperatures, making proper installation difficult.

You are now ready to begin the installation process.

INSTALLATION: GETTING STARTED

To make installation easier, we recommend that two people install the top.

Make sure that the temperature where you are going to install your Convertible Top is at least 70°F (21°C). If it is cooler than this outside, we suggest you install your top in a heated garage. Do not try to install your Convertible Top in temperatures less than 70°F (21°C) because proper installation will not be possible.

Tools You Will Need

- A phillips head screwdriver
- An adjustable wrench
- A tape measure
- A hammer
- 1 ea. 1/8", 5/32" and 3/16" drill bits and a power drill
- Scissors
- A center punch
- A piece of chalk
- A pencil

UNPACKING: WHAT YOU HAVE

Important - Please Read

Even though Bestop has taken every possible precaution to include all the parts necessary to install your Convertible Top, sometimes pieces are unintentionally left out. **DO NOT RETURN YOUR CONVERTIBLE TOP.** Immediately contact Bestop at 1(800)346-3910 or, in Colorado, at (303)465-1755. We will then be able to forward the necessary part to you or have you contact a local distributor to ensure the most expedient service.

Carefully remove the parts from the shipping container to avoid scratching the windows. Check each part against the following parts list.

USE ONLY PARTS THAT COME WITH THIS TOP, SINCE OLD PARTS MAY NOT MATCH.

NOTE: On vehicles built after 1975 that have never had a soft top, a metal tailgate panel will need to be ordered. Order Part Number 51042-01. (Removing the hard top also removes the tailgate).

NOTE: The Horizontal Assemblies mount to the existing brackets in the upper corners of the vehicle windshield. If the brackets are missing, order Part Number 13.85.

INSTALLING YOUR CONVERTIBLE TOP

Regardless of what type of hardware you currently have on your vehicle, it is extremely important that you only use the hardware found in this Convertible Top kit. This Convertible Top can not be used with your existing hardware.

WINDSHIELD ADJUSTMENT

This is the first step you must take in the installation process and it is also the most important one. Improper windshield adjustment results in poor fitting of both the top and the doors, as well as misalignment of snaps.

Step One: Measure and record the distance from the top inside edge of the windshield to the top outer edge of the vehicle body (see Figure 1). Take the measurement from approximately six inches inside the vehicle's doors. Check to make sure that both sides measure equally. To install this top properly, this measurement must be 81".

FIGURE 1

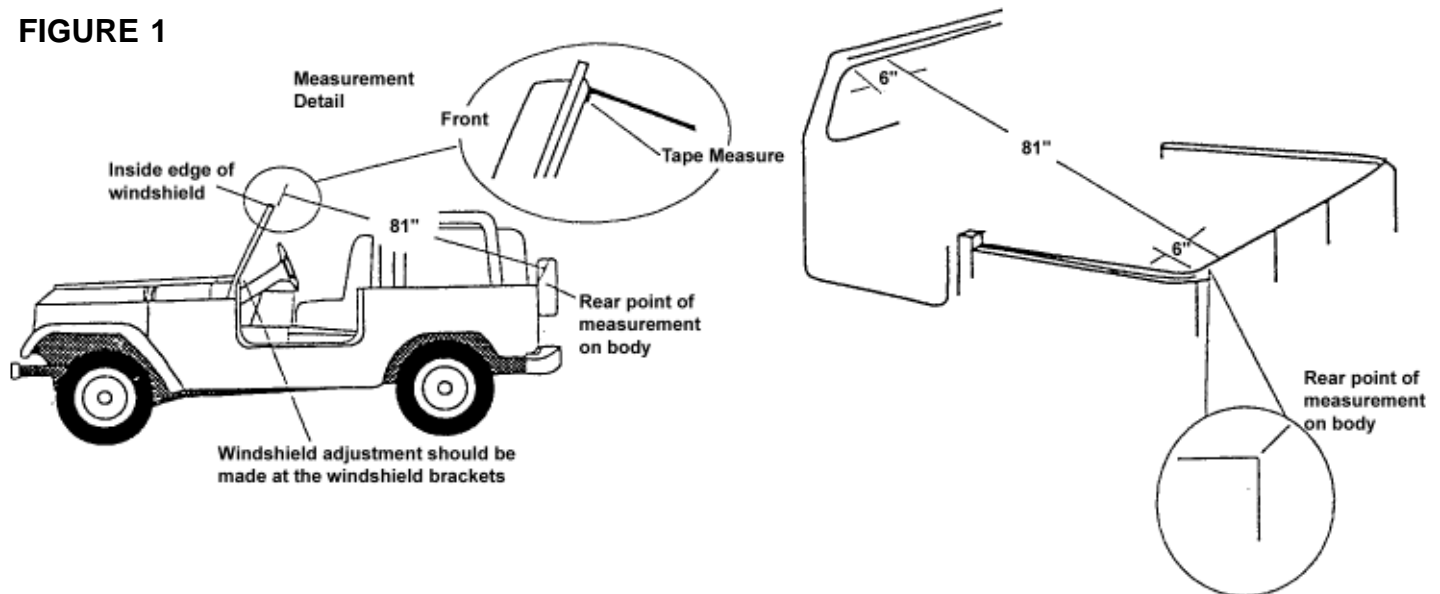

Step Two: Adjust your windshield by loosening the Windshield Clamps and adjusting the brackets. You may then lean the windshield forward or back as necessary. Use a shim to fix the windshield in place if it remains loose after you tighten the screws.

IMPORTANT NOTE: Before continuing, please check the following items:

Part Number: 51444

Model: Toyota Land Cruiser, FJ40, BJ40, 1964-1984. Top Kit, Soft Doors Included

NOTE: Use of this product on some vehicles may not allow the use of factory side mirrors.

Use of this product on some vehicles may require the removal of the entry light bulbs.

On vehicles built after 1975 that have never had a soft top, a metal tailgate panel will need to be ordered. Order Part Number 51042-01. (Removing the hard top also removes the tailgate).

Parts List and Hardware Identification

Check off each item

Bow Assembly - Right,
 Qty - 1, PN 244.52

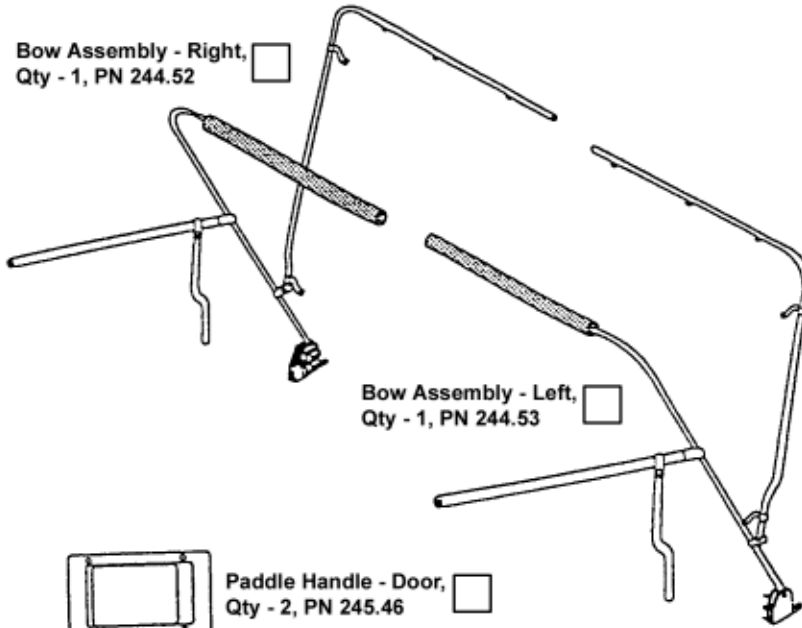

Bow Assembly - Left,
 Qty - 1, PN 244.53

Paddle Handle - Door,
 Qty - 2, PN 245.46

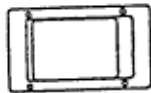

#8 x 1/2" Pan Head
 Washer Screw - Black,
 Qty - 9, PN 200.48



#14 Sheet Metal Screw,
 Qty - 4, PN 243.51

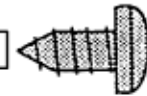

#10-24 x 3/8" Truss Head
 Machine Screw - Black,
 Qty - 8, PN 195.92



#10-24 Locknut,
 Qty - 8, PN 195.93



Wing Nut, Qty - 2,
 PN 151.83

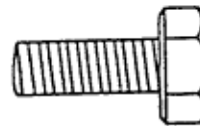

5/16" x 3/4" Hex Bolt,
 Qty - 2, PN 116.03

#10 x 1/2" Oval Head
 Phillips Screw,
 Qty - 4, PN 155.49



Footman Loop,
 Qty - 2, PN 272.29

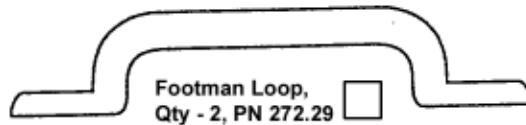

Bow Coupler,
 Qty - 2, PN 244.73



Threaded Body Stud,
 Qty - 24, PN 151.81

Handle - Clip on,
 Qty - 2, PN 223.47



#10-32 Hex Nut,
 Qty - 24, PN 151.82



Windshield Retainer
 Right, Qty - 1, PN 225.42

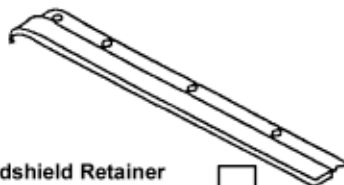

Windshield Retainer
 Left, Qty - 1, PN 225.43

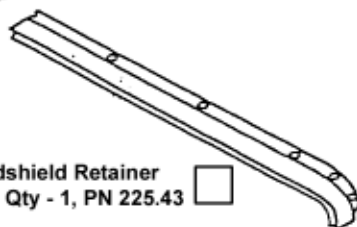

Door Striker,
 Qty - 2, PN 244.72

- Top Fabric Qty - 1
- Door - Right Qty - 1
- Door - Left Qty - 1
- Zipper Pulls Qty - 2
- Adhesive PSA Hook Strap Qty - 8
- Buckle Strap Qty - 2

Because of Generic Packaging, extra parts may be included.

THE MOUNTING ASSEMBLY

This section will lead you through the installation of the various pieces that make up your Convertible Top hardware system.

BOW ASSEMBLY

CAUTION: Installation of the Bow Assemblies involves drilling in the top edge of the vehicle body. Check under the body edge at the marked locations. There may be wiring for the rear lights. If so, pull the wiring out of the way before drilling.

NOTE: It may be necessary to remove any Roll Bar Padding.

Step One: Measure 15 1/2 Inches along the top edge of the vehicle from the door jam (see Figure 2). Mark the locations with a pencil on each side of the vehicle. This will be the location of the front hole of the Bow Assembly Mounting Brackets.

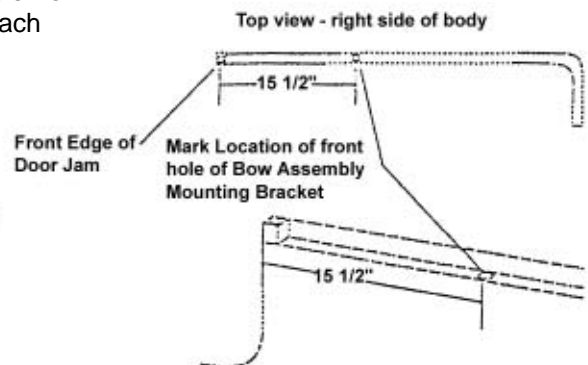
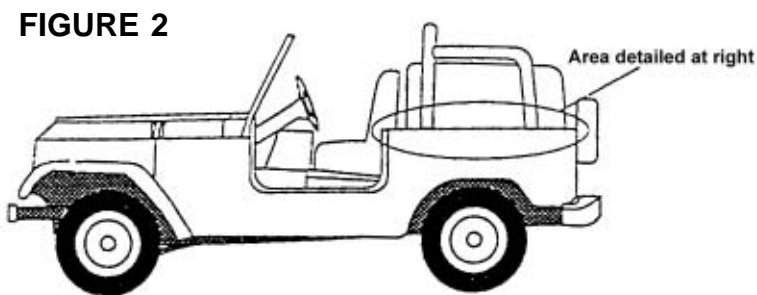

Step Two: This step will require two people. Locate the left and right Bow Assemblies in the parts kit. Select one of the assemblies and lay the assembly on the body. Center the front hold of the Bow Assembly Mount Bracket on the 15 1/2 inch mark. Using the Bow Mounting Bracket as a template, center punch and drill a 3/16" hole. Secure the front hole of the Bow Assembly Mount Bracket as a template, mark, center punch and drill a 3/16 inch hole for the rear of the bracket. Secure the rear hole with a #14 Sheet Metal Screw. Repeat this procedure on the opposite side of the vehicle. Lay the Bow Assemblies down onto the body and connect the Bow Halves together with the Bow Couplers. Slide the foam sleeves on the front bow to the center of the Bow Coupler on the front Bow Assembly.

NOTE: The flat side of the front Assemblies will mount to the outside of the existing windshield bracket.

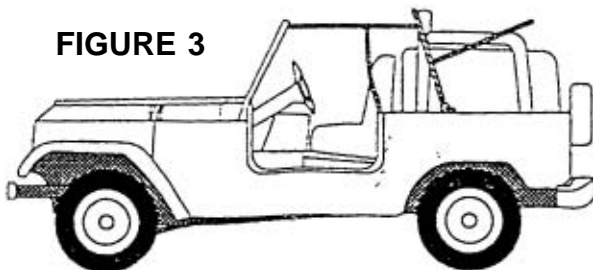
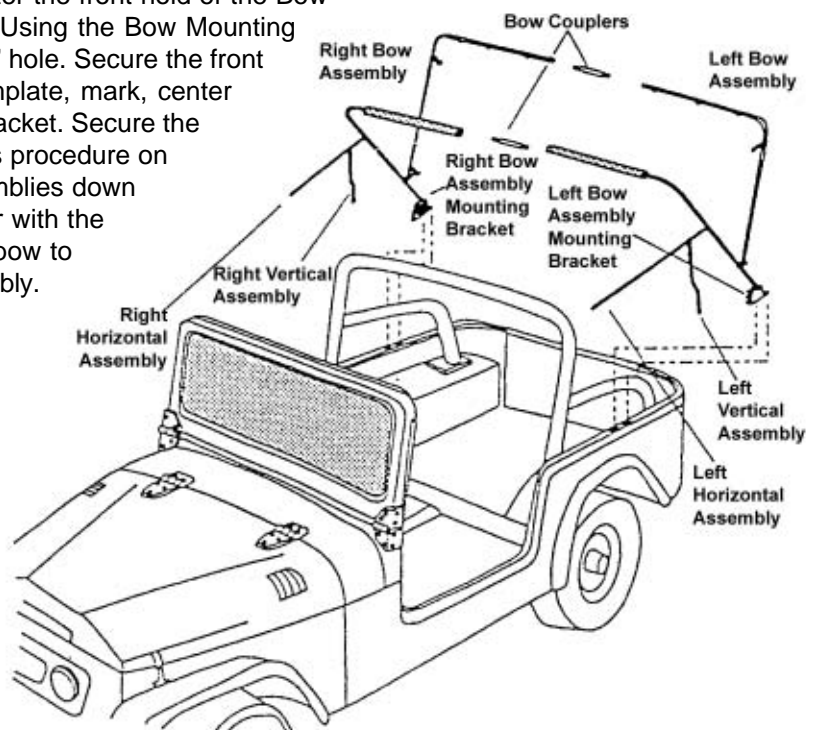

Step Three: Rotate the Front Bow Assemblies forward and insert the Vertical Assemblies into the existing hole on the top of the body at the rear of the door openings. Secure the front of the Horizontal Assemblies to the existing brackets in the upper corners of the windshield frame using a 5/16 X 3/4" Hex Bolt and Wing Nut.

NOTE: The Horizontal Assemblies mount to the existing brackets in the upper corners of the vehicle windshield. If the brackets are missing, order Part Number 13.85.

WINDSHIELD RETAINER

NOTE: If your vehicle currently has a windshield retainer, it must be removed and replaced with the enclosed windshield retainer.

Step One: Center the Windshield Retainers on top of the windshield frame and butt the retainers up against the top lip of the windshield frame. Use the retainers as a template to mark, center, punch and drill nine 1/8 inch holes (Note: drill one 1/8 inch hole between the two halves of the retainer). Use nine #8 1/2 Pan Head Washer Screws (see Figure 4).

NOTE: There may be existing holes on some vehicles that may interfere with the holes in the new windshield retainers. If so, it may be necessary to drill the retainer holes off to one side.

CAUTION: A loose windshield retainer may allow the top to disengage from the windshield, causing damage to the top and possible injury to the occupants of the vehicle. Make certain that the windshield at the time of first installation. Check the tightness of the mounting screws every three months. (Do not overtighten).

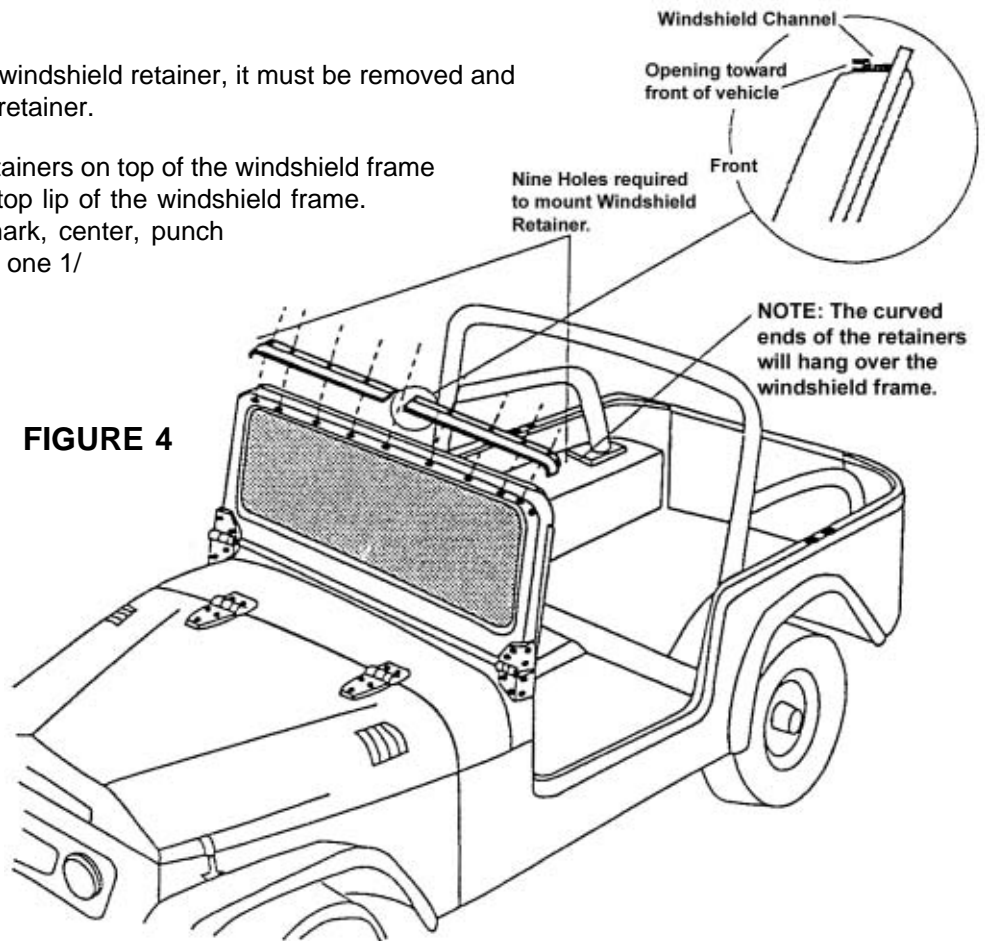

FOOTMAN LOOPS

CAUTION: Installation of the Footman Loops involves drilling in the top edge of the vehicle body. Check under the body edge at the marked locations. There may be wiring for the rear lights. If so, pull the wiring out of the way before drilling.

Step One: Install the Footman Loops on the top rear corners of the vehicle. Use the loops as templates to mark, center, punch and drill 5/32 inch holes. Use two #10 X 1/2 Oval Head Phillips Screws to secure the loops in place (see Figure 5).

FIGURE 5

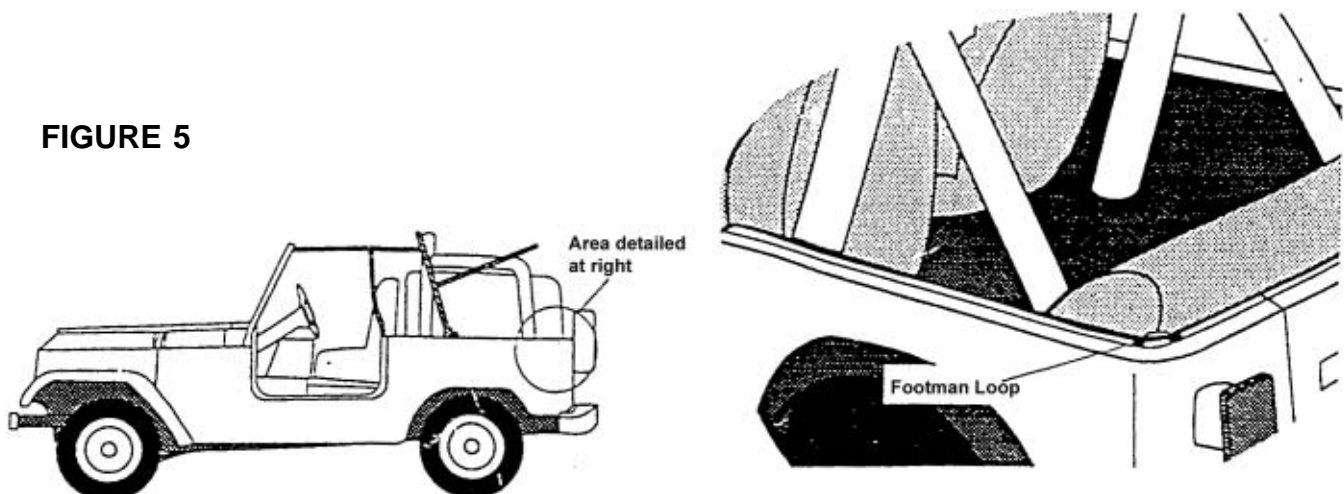

TOP FABRIC INSTALLATION

This section will require two people.

NOTE: On vehicles built after 1975 that have never had a soft top, a metal tailgate will need to be ordered. Order Part Number 51042-01. (Removing the hard top also removes the tailgate.)

Step One: Unfold the top and drape it over the front bow. Slip the black plastic strip sewn along the front of the top into the windshield Retainers. Make sure that the fabric is centered on the windshield. Failure to center the fabric could result in torn fabric.

Step Two: Lift the Rear Bow and drape the top over it. Snap the flaps on the inside of the top to the studs on the Rear Bow. Locate the Buckle Straps in the parts kit. Wrap each strap around the corners of the Rear Bow and snap the straps to themselves. This strap will hold down the Rear Bow when the Rear Curtain and Side Panels are rolled up.

INSTALLING THE BODY STUDS

The following steps are crucial to the proper installation of the top. This step will require two people. Make sure that the top fabric is as warm as possible before beginning.

Step One: Close the zippers on the Rear Curtain. Locate the three holes grouped together on each Front Bow. These holes adjust the tightness of the top. Slide the Rear Bow Assembly and the bow release (both sides) up on the Front Bow Assembly and slip the small, bent tab of the bow release into the center hole on the Front Bow (see Figure 6).

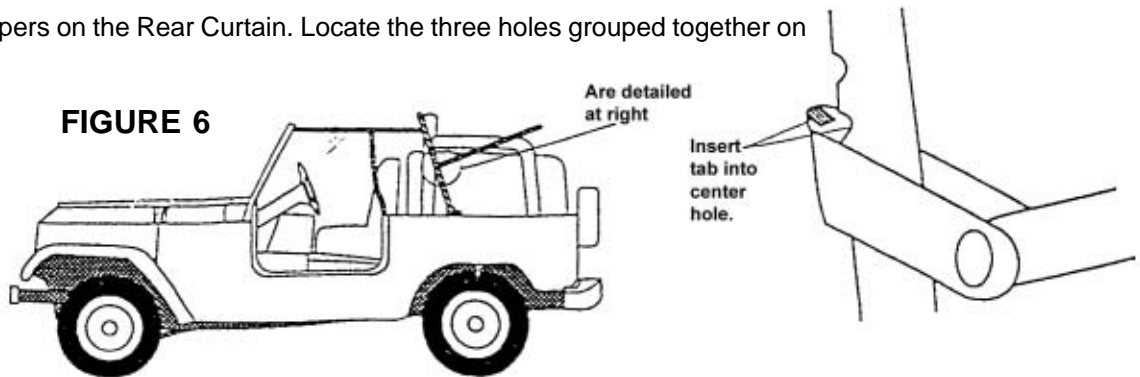

Step Two: Rub chalk on the snaps on the inside of the top to mark the stud locations.

Step Three: Move to the front of one of the side panels. Pull the top fabric down and press the snaps against the body. The chalk will leave

FIGURE 7

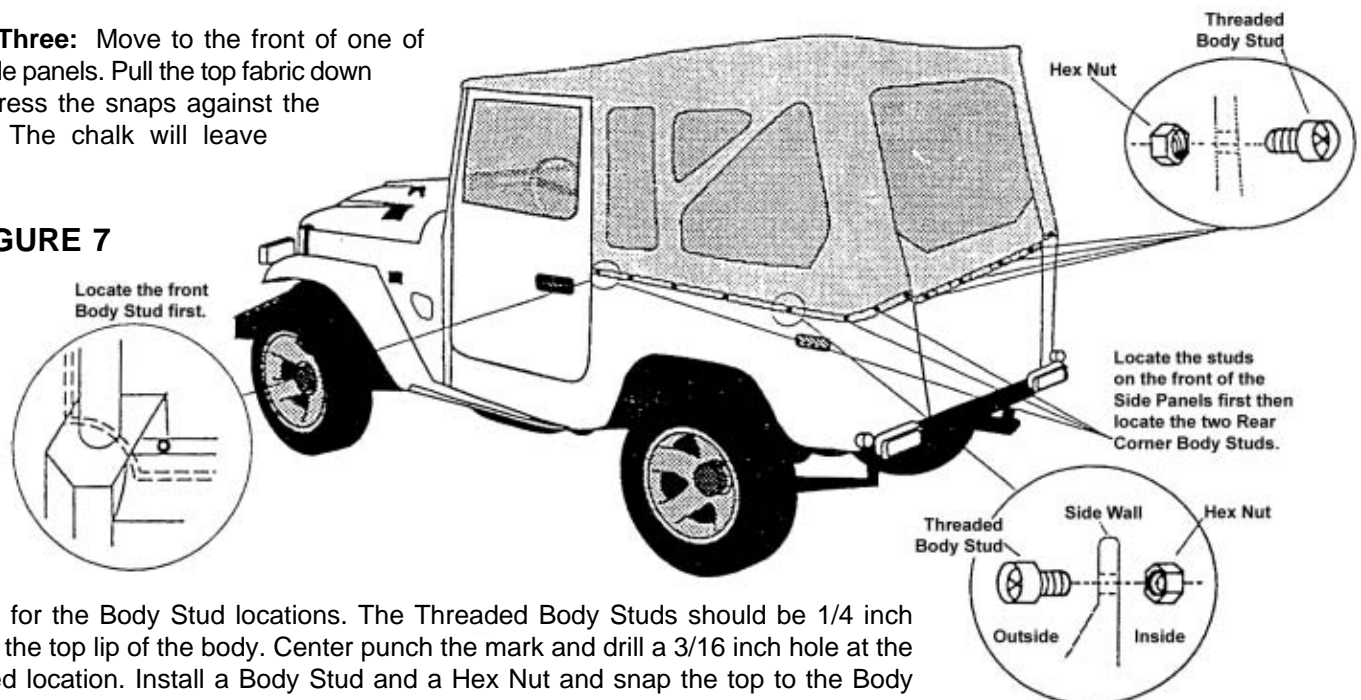

marks for the Body Stud locations. The Threaded Body Studs should be 1/4 inch below the top lip of the body. Center punch the mark and drill a 3/16 inch hole at the marked location. Install a Body Stud and a Hex Nut and snap the top to the Body Stud. Repeat this procedure on the other side of the vehicle.

Step Four: To ensure a good fit, have one person pull down on the rear bow while the other person pulls the fabric down and to the rear to locate the rear corner studs. When you are satisfied with the tightness of the top, press the snaps against the body. The chalk will leave marks for the Body Stud locations. The Threaded Body Studs should be 1/4 inch below the top lip of the body. Center punch the marks and drill 3/16 inch holes at the marked locations on each rear corner. Install a Body Stud and hex Nut in the rear corners. Snap the top to the corner body studs.

Step Five: Install the remaining Threaded Body Studs on the Side Panels and the Tailgate. Alternate from side to side as you install the studs and snap the top to each new stud. This will keep the tension of the top evenly spread.

Step Six: Thread the buckle strap assembly through each Footman Loop and then back through the buckle. Do not over tighten. Wrap the fabric flaps, sewn to the top above and behind the doors, around the Horizontal and Vertical Assemblies and fasten the hook and loop fasteners. Cut the PSA Hook in half and assemble the PSA Hook on the bevel of the vehicle, where the two side curtains zip together.

NOTE: The weather strip in the vertical flap should lay to the outside of the Vertical Assembly.

DOOR INSTALLATION

Step One: Fold the fabric back and insert the Paddle Handle into the Paddle Handle Mount on the rear lower part of each door frame. Make sure that the latch is toward the rear of the door. Use four #10-24 X 3/8 Truss Head Machine Screws and four #10-24 Locknuts to secure each paddle Handle in place. Do not fully tighten the screws at the point because they may have to be moved during the door adjustment. Attach the Clip On Door Handles to the horizontal rod on the door frame (see Figure 9).

WARNING: Clip-on handle is designed to aid in door closure. This handle will not support a person's weight.

Step Two: Check that the hinge pins, welded to the door frames, are aligned along the same axis. Sight along the hinge pin axis or lay a straight edge against them. If they have been bent in handling, they must be straightened before the doors are hung on the vehicle. If necessary, use a 9/16 inch box wrench to gently bend the pin into the proper position. Oil the pins with a light weight oil. Install the doors by holding them straight out from the vehicle with the door pins over the body hinge. Lower the pins into the hinge. Swing the door back and forth until the pins are fully inserted into the body hinge. When the pins are properly adjusted, the doors should slip easily into the body hinges without forcing them.

Step Three: Close the door and check all sides to make sure that the door fits properly against the body. If necessary, the door may be bent slightly to fit the contour of the vehicle body. Tie the zipper pulls to the zipper sliders (see Figure 11).

FIGURE 9

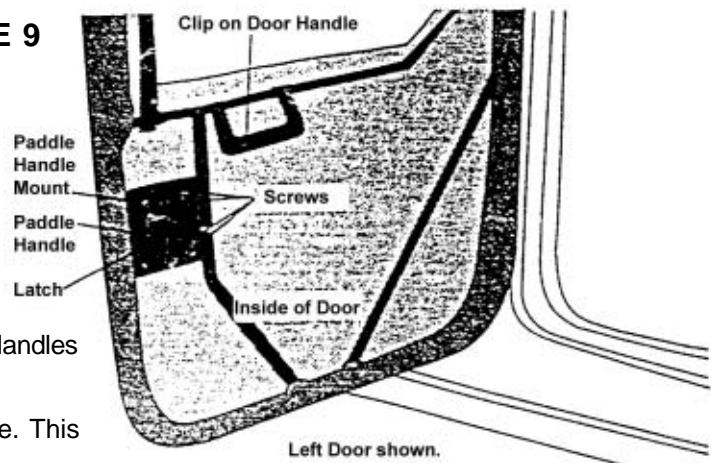

FIGURE 10

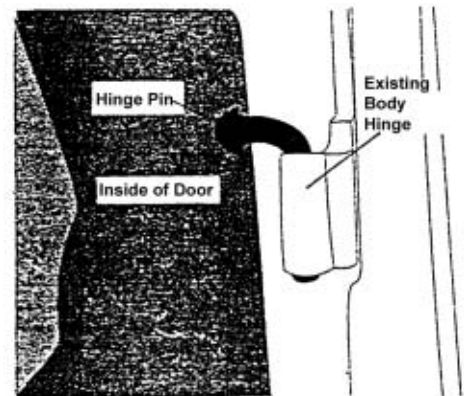
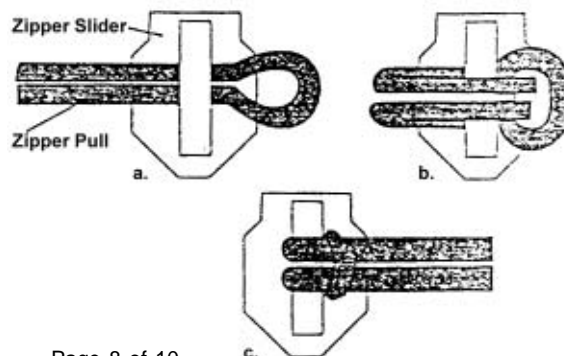

FIGURE 11



DOOR STRIKE INSTALLATION

NOTE: If a hard door strike is present, it must be removed.

NOTE: Some vehicles will use the existing holes and bolts from the hard door strike.

Close the door against the body and locate the Door Strike behind the Paddle Handle Latch. Mark the center of the slots in the Door Strikes. Center punch and drill two 3/16 inch holes. Secure the Door Strikes with two #14 Sheet Metal Screws. The Door Strikes may be adjusted in or out until you are satisfied with the way the door shuts and opens. Tighten the machine screws on the paddle Handle and trim any excess fabric from around the Paddle Handles. (Leave 1/4 inch of fabric around the inside of the Paddle Handle.)

FIGURE 12

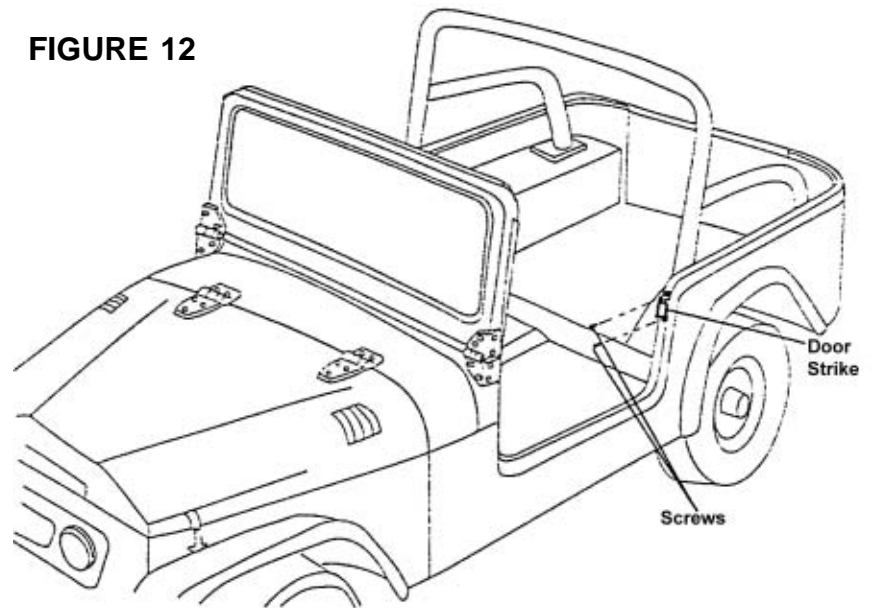

ADJUSTING THE TOP

Rear Curtain

To roll up the Rear Curtain, start at the bottom and roll it to the inside. Avoid wrinkles in the fabric and window. Secure it in place with the curtain strap inside of the top (see Figure 13).

FIGURE 13

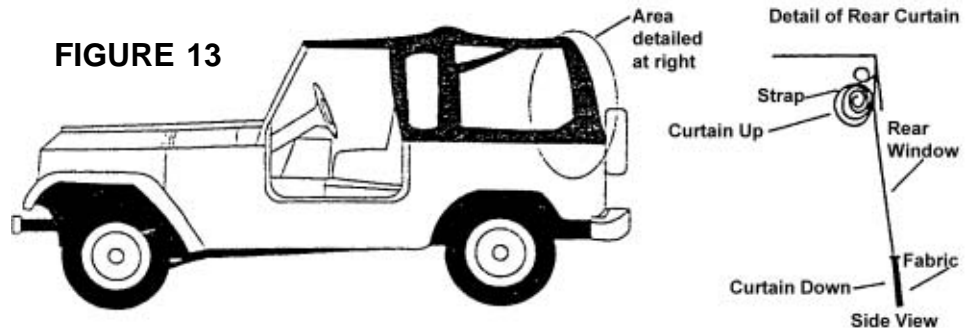

Side Curtain

The small Front Side Curtain may be left in the down position while the Rear Side Curtain is in the up position. To roll up the Side Curtains, fold the bottom rear corner of the panel forward and roll the curtain to the outside. Avoid wrinkles in the fabric and the windows. Secure the curtain in place with the curtain straps inside the top (see Figure 14).

FIGURE 14

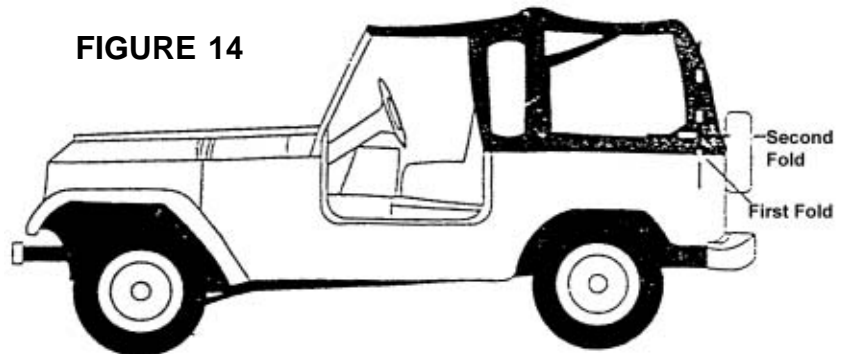

FOLDING THE TOP DOWN

Step One: Unsnap the Rear and Side Curtains and unzip the Rear Curtain zippers. Fold the Side Curtains along the seam and up over the top. Fold the Rear Curtain up over the Side Curtains. Unfasten the hook and loop fasteners around the Vertical Retainer and the Horizontal Rod. Release the locking tabs on the bow releases from the holes in the Front Bow and slide the Rear Bow down to the Bow Mounts. Insert the bow release tab into the hole on the Front Bow, just above the Bow Mount. Remove the Vertical Retainer and the Horizontal Rod from their mounts and pivot the Front Bow to the rear of the vehicle until it makes contact with the Rear Bow (see Figure 15).

FIGURE 15



Step Two: Unfasten the top from the Windshield Retainer and lay the top down on the body (see Figure 16). Fold the top in half from front to back and continue folding until the top is about one foot wide at the rear of the vehicle (see Figure 17). The Buckle Strap assemblies may be used to secure the top to the bow assembly.

FIGURE 16

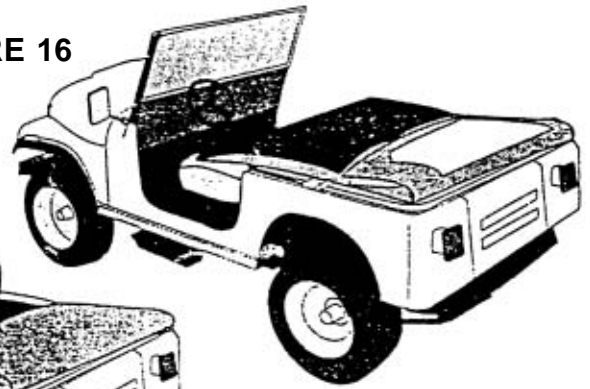
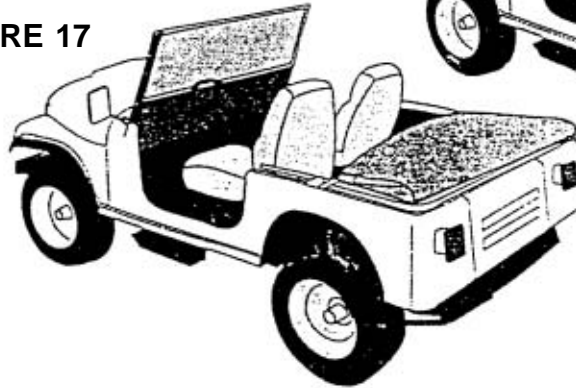

FIGURE 17



Step Three: Secure the Vertical Retainers and the Horizontal Rods by snapping each of the Bow Tie Down Straps to a body stud. Secure the rear portion of the bow assemblies by snapping each of the Bow Tie Down Straps to a corner body stud.

CARE AND MAINTENANCE OF YOUR BESTOP TOP

Your top is made of the finest materials available. To keep it looking new and for the maximum possible wear, it will need periodic cleaning and maintenance.

WASHING: The top fabric should be washed often using soap, warm water and a soft bristle brush. Rinse with clear water to remove all traces of soap. A vinyl protector can be used on the vinyl side of the fabric.

WINDOWS: Keep windows clean to avoid scratching. DO NOT use a brush on the windows! Wash with a water soaked cloth or sponge and a mild dishwashing detergent. NEVER WIPE THE WINDOWS WHEN THEY ARE DRY. Be careful when cleaning snow or frost from the vinyl windows since they are easily scratched and may crack at low temperatures. DO NOT roll the sides or rear curtain in cold weather. The windows become stiff and will crack.

ZIPPERS: Keeping the zipper cleaned and lubricated with a silicone lubricant will help prevent damage and keep the zippers in a smooth working condition. If a zipper opens behind the slider, the slider may have been spread apart. This problem can usually be repaired by using an ordinary pair of pliers to bring the sides back into parallel. Return slider to the end of the zipper in the normal Open position. Squeeze lightly at first and test the zipper. If the zipper continues to remain open, squeeze more firmly with the pliers and try the zipper again. Repeat this procedure until the zipper operates correctly.

WATER: Seeping through at the seams may be stopped by applying 3-M Scotchgard® on the inside of the seams. Rips in the fabric may be repaired with Bondex® iron on patches. Iron the patches to the Inside of the top, carefully following the Bondex® instructions.

SNAPS: Keep snaps cleaned and lubricated with silicone to help prevent snaps from sticking to the studs. If a snap does become stuck to a stud, use a screwdriver and GENTLY pry apart to prevent permanent damage to the snap or the top fabric.

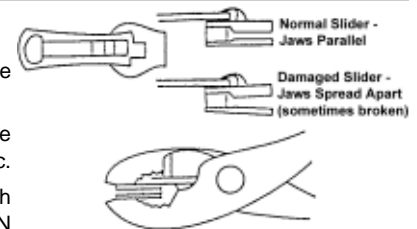

LIMITED WARRANTY

Bestop, Inc. warrants this product to be free from defects in material, for the terms specified below, provided there has been normal use and proper maintenance. This warranty applies to the original purchaser only. All remedies under this warranty are limited to the repair or replacement of any item or items found by the factory to be defective within the time period specified.

If you have a warranty claim, first you must call the factory at the number below for instructions. You must retain proof of purchase and submit a copy with any items returned for warranty work. Upon completion of warranty work, if any, Bestop will return the repaired or replaced item or items to you freight prepaid. Damage to our products caused by accidents, fire, vandalism, negligence, misuse, Acts of God, or by defective parts not manufactured by us is not covered under this warranty.

THE TERMS OF BESTOP'S WARRANTY ARE AS FOLLOWS: "SOFT GOODS" MANUFACTURED BY BESTOP, INC. (USING PRIMARILY VINYL, PLASTICS, AND/OR FOAM): 90 DAYS FROM DATE OF PURCHASE.

ANY IMPLIED WARRANTIES OF MERCHANTABILITY AND/OR FITNESS FOR A PARTICULAR PURPOSE CREATED HEREBY ARE LIMITED IN DURATION TO THE SAME DURATION AS THE EXPRESS WRITTEN WARRANTY. OUR COMPANY SHALL NOT BE LIABLE FOR ANY INCIDENTAL OR CONSEQUENTIAL DAMAGE, INCLUDING, WITHOUT LIMITATION, DAMAGES RESULTING FROM THE USE OF THE PRODUCT ON REPAINTED SURFACES (NON-FACTORY ORIGINAL PAINT) AND FADING AND PAINT COLORATION DIFFERENCES RESULTING FROM THE PRODUCT'S SHIELDING PORTIONS OF SURFACES FROM EXPOSURE TO THE SUN AND ELEMENTS WHILE OTHER ADJACENT SURFACES REMAIN COMPLETELY EXPOSED.

Some states do not allow limitations on how long an implied warranty lasts, or the exclusion or limitation of incidental or consequential damages, so the above limitations or exclusions may not apply to you.

This warranty gives you specific legal rights, and you may also have other rights which vary from state to state.

For further information or request for warranty work, please call: Bestop Inc.
Consumer Response
(303) 465-1755